



# **State Road (SR) 5/US 1 from SR870/ Commercial Boulevard to SE 7th Street Resurfacing, Restoration and Rehabilitation (RRR) Project**

Project Identification Number: 446188-1-52-01

Public Information Meeting | September 7, 2022

# Agenda

- 1. Introductions**
- 2. Technical Information**
- 3. Non-Discrimination Policy**
- 4. Rules of Engagement**
- 5. FDOT Safety Message**
- 6. Project Overview**
- 7. Design Plans**
- 8. Maintenance of Traffic**
- 9. Questions and Answers**
- 10. Contact Information**

# 1. Introductions

# Project Team



**Helen James, P.E.**  
Project Manager  
Florida Department of Transportation



**Scott Horlander, P.E.**  
Consultant Project Manager  
KEITH



**Cecilia Villoria, P.E.**  
Consultant Roadway Designer  
KEITH

## 2. Technical Information

# Participating on GoToWebinar



# For Dial-In by Phone Attendees

Dial-in attendees are **'listen only'**



If you requested or downloaded the presentation

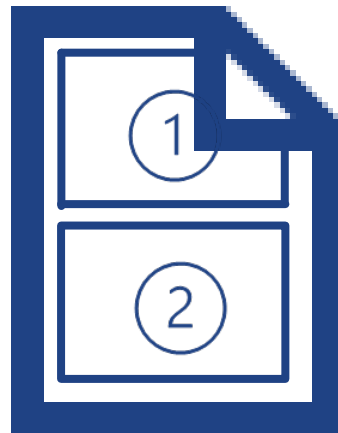

Paper copy of presentation

“Now showing slide 4.”



Presenter will indicate slide number

[https://www.d4fdot.com/tcfdot/future\\_projects\\_index.asp](https://www.d4fdot.com/tcfdot/future_projects_index.asp)

# To report a technical issue...



Type in  
**Question box** on  
GoToWebinar  
Control Panel



**Call**  
1 (833) 851-8340



# Virtual Public Meeting - Public Notice



Property Owner/Tenant Letters



Social Media

*@myFDOT\_SEFL and @myFDOTSEFL*

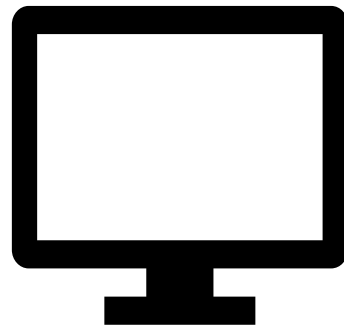

FDOT Website



Florida Administrative Register

# 3. Non-Discrimination Policy

The Florida Department of Transportation complies with various non-discrimination laws and regulations, including:

**Title VI of the Civil Rights Act of 1964**

*This meeting is being held without regard to race, color, national origin, age, sex, religion, disability, or family status.*

For questions or concerns, you may contact either:

**District Four**

Florida Department of Transportation  
*District 4 Title VI Coordinator*

**Sharon SinghHagyan**

 3400 West Commercial Boulevard  
 Fort Lauderdale, Florida 33309

 (954) 777-4190

 [Sharon.SinghHagyan@dot.state.fl.us](mailto:Sharon.SinghHagyan@dot.state.fl.us)

**Tallahassee Office**

Florida Department of Transportation  
*State Title VI Coordinator*

**Jacqueline Paramore**

 605 Suwannee Street, MS 65  
 Tallahassee, Florida 32399

 (850) 414-4753

 [Jacqueline.Paramore@dot.state.fl.us](mailto:Jacqueline.Paramore@dot.state.fl.us)

# 4. Rules of Engagement

# Rules of Engagement



- This Public Information Meeting is being recorded.
- If you experience technical difficulties, please contact **+1 (833) 851-8340** so that a member of our technical support team may assist you.
- All attendees **will remain muted** throughout the meeting except for the **Open Discussion**.
- At the end of the presentation attendees are also welcome to submit any questions/comments using the GoToWebinar Question Panel and a member of the team will respond during the question-and-answer portion. To request to speak, click the Raise Hand button on the Control Panel and unmute your microphone when your name is called.

# 5. FDOT Safety Message

# FDOT Safety Message

## WORK ZONE SAFETY It's Everyone's Job

**21%** of fatal work zone crashes involved rear-end collisions.



**LEAVE EXTRA SPACE  
BETWEEN VEHICLES**

† 2018 NHTSA Data - [ops.fhwa.dot.gov/wz/outreach/nwzaw\\_factsheet\\_2020/index.htm](https://ops.fhwa.dot.gov/wz/outreach/nwzaw_factsheet_2020/index.htm)

# FDOT Safety Message

## WORK ZONE SAFETY It's Everyone's Job



### TIPS FOR ROAD USERS

- **WATCH** for vehicles entering and leaving the roadway.
- **BE AWARE** of workers while driving through an active work zone.
- **SLOW DOWN**, follow the posted speed limit.
- **SAVE LIVES**, avoid distractions and always drive sober.





# 6. Project Overview

# Project Location

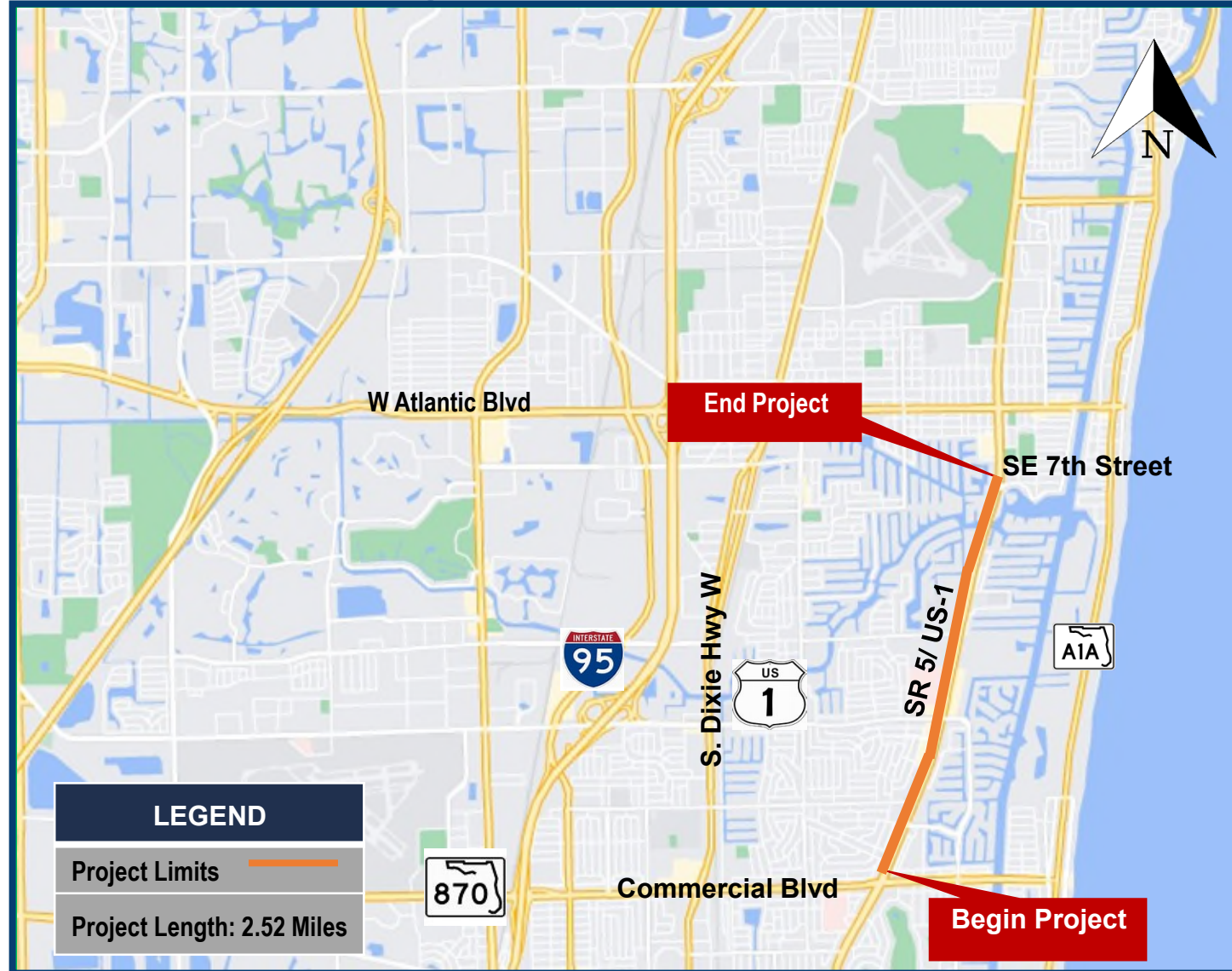

# 7. Design Plans

# Existing Conditions

- SR 870/Commercial Boulevard to SE 7th Street
  - Typical Section 1 (Mile Post (MP) 5.736 to MP 8.036 and MP 8.084 to MP 8.254)

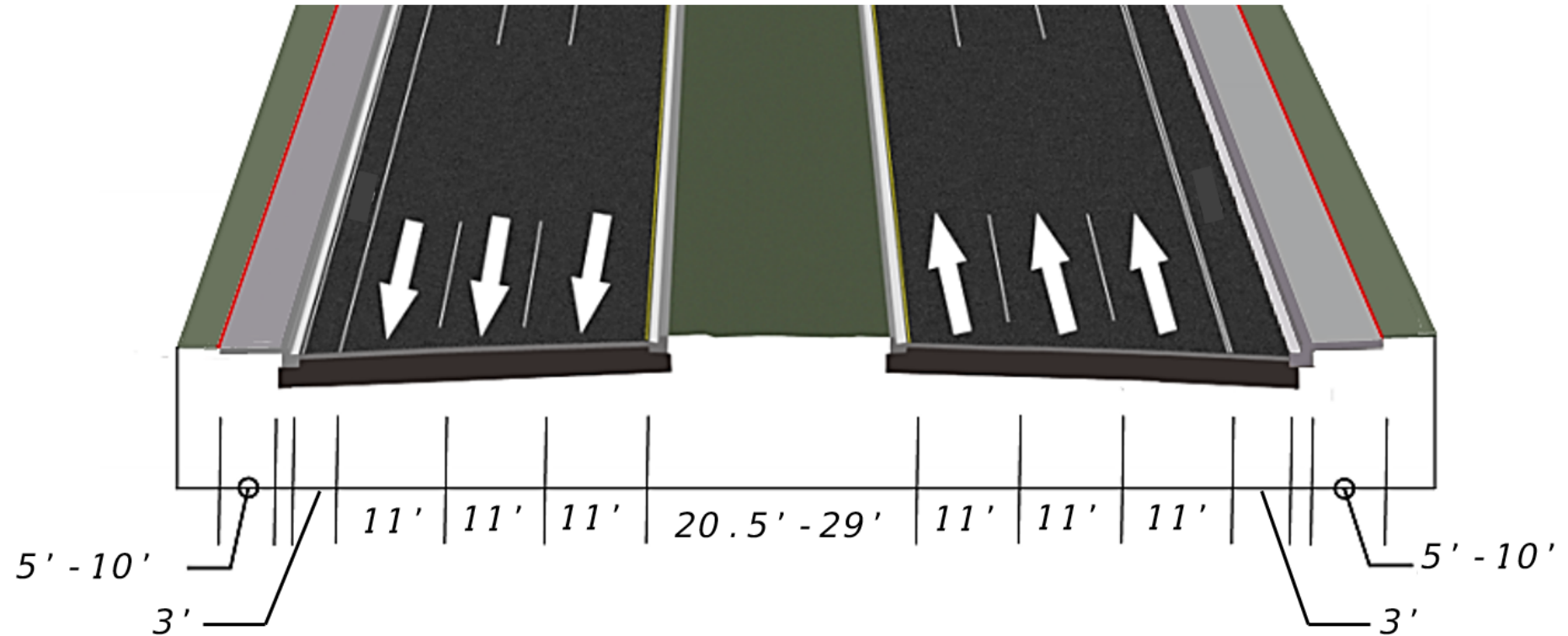

# Existing Conditions

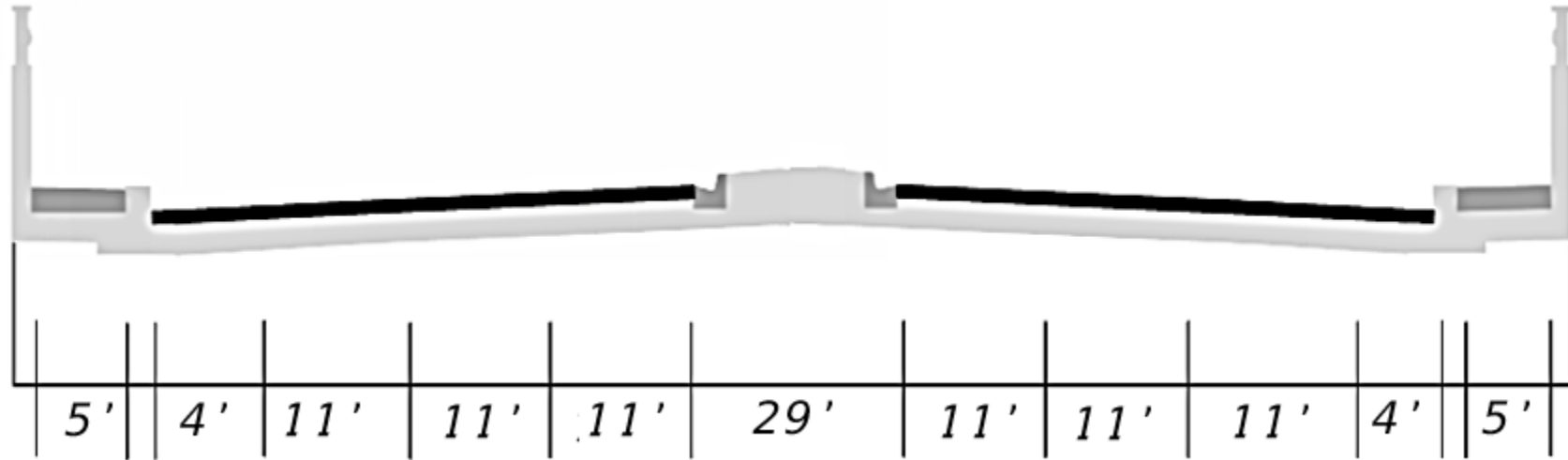

**Typical Section 2 (Bridge #860222 over Canal C-14/Cypress Creek)**



# Proposed Roadway Concept

- SR 870/Commercial Boulevard to SE 7th Street
  - Typical Section 1 (Mile Post (MP) 5.736 to MP 8.036 and MP 8.084 to MP 8.254)

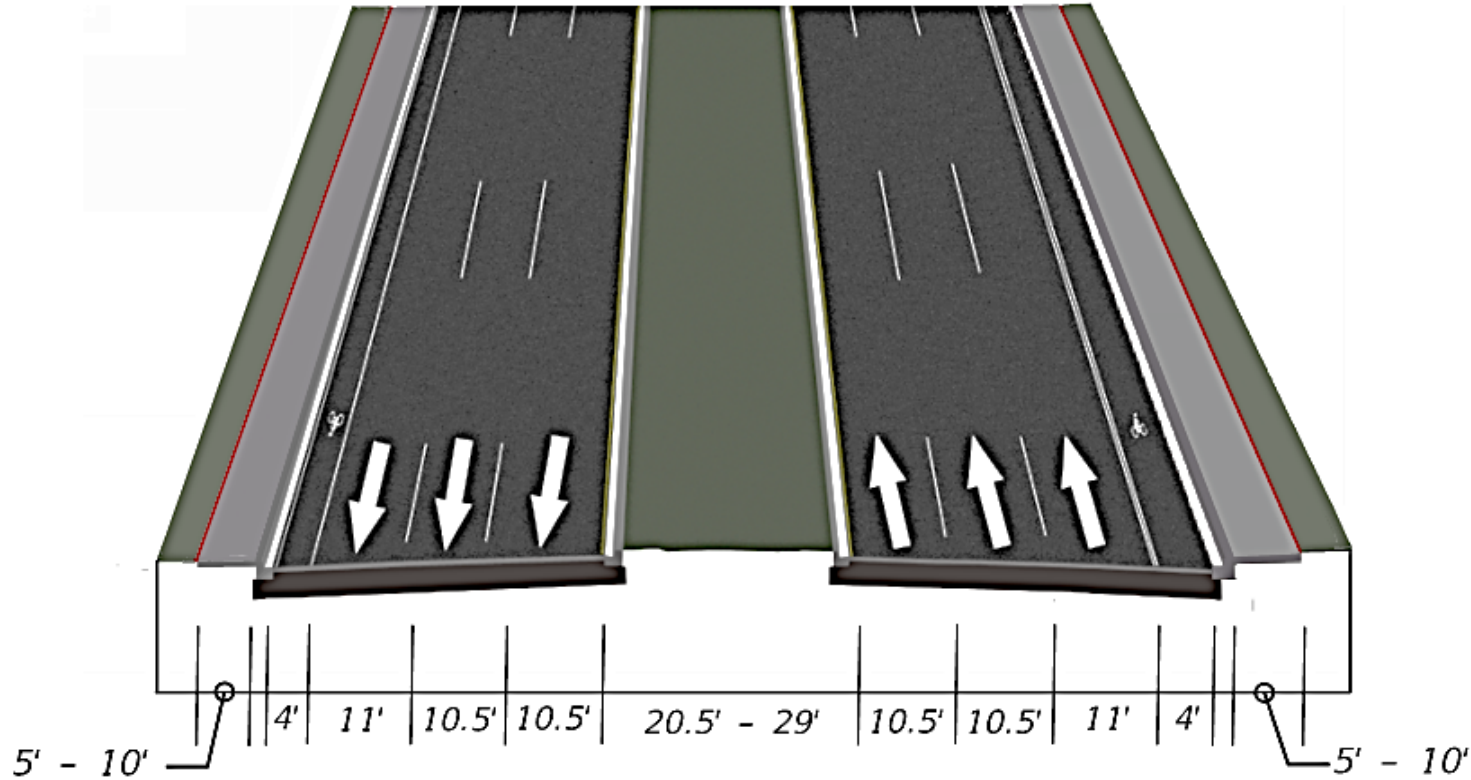

# Proposed Roadway Concept

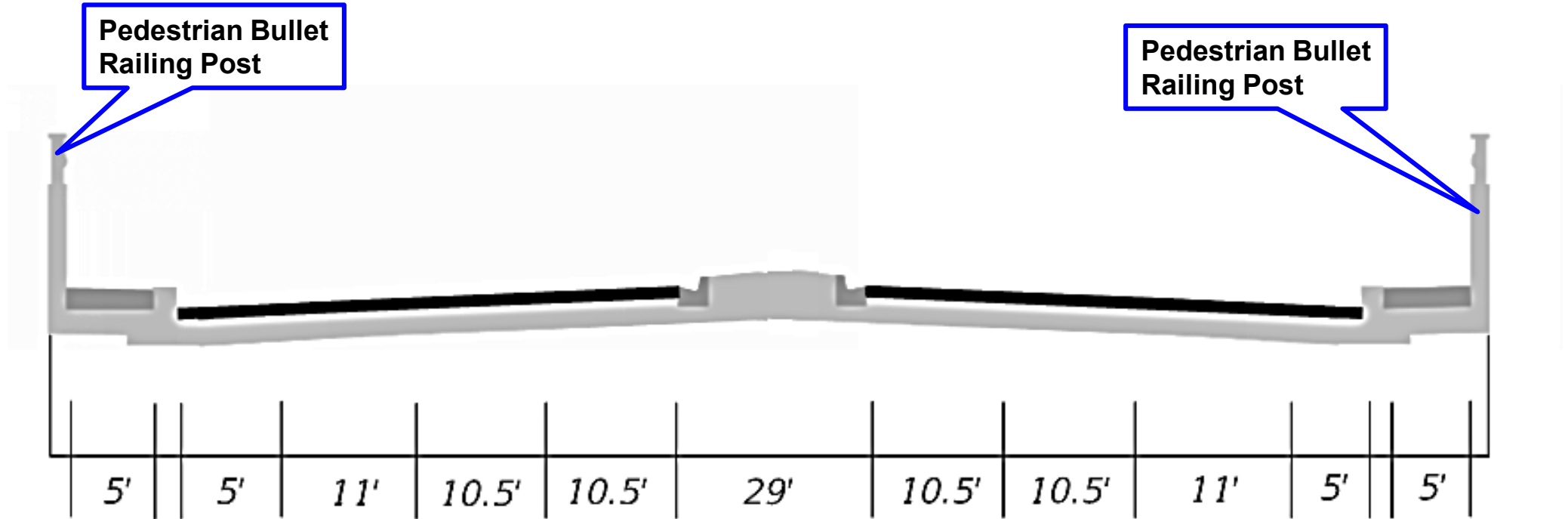

Typical Section 2 (Bridge #860222 over Canal C-14/Cypress Creek)



# Proposed Project Safety Enhancements

- Repave the existing travel lanes.



- Install new signing and pavement markings.

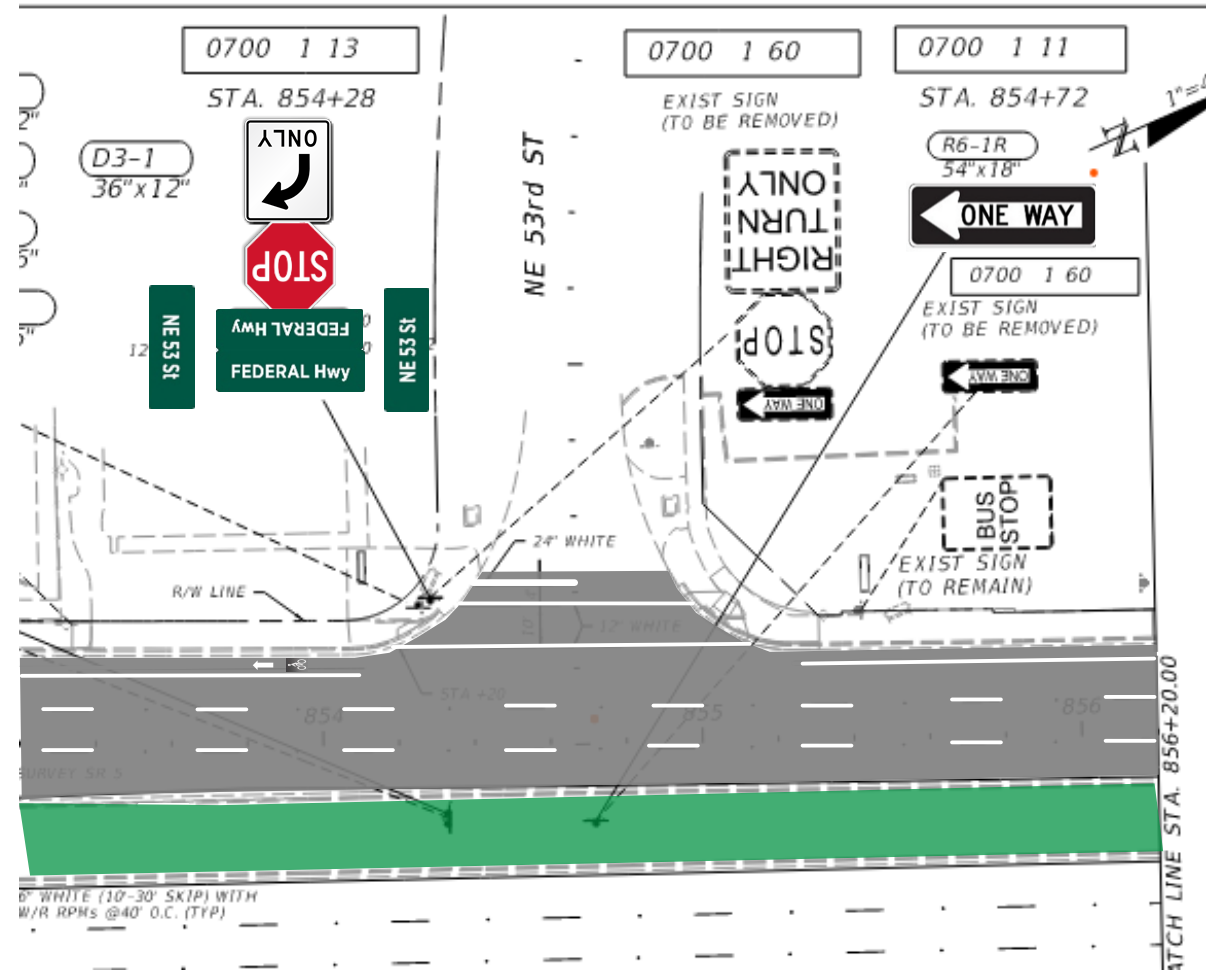



# Proposed Project Safety Enhancements

- Reduce width of the existing travel lanes to create space for bicycle lanes.



- Replace and upgrade existing curb ramps to comply with Americans with Disabilities Act (ADA) standards.



# Proposed Project Safety Enhancements

- Upgrade existing bridge railing at bridge #860222 over Cypress Creek Canal.
- Upgrade pedestrian push button countdown detectors at signalized intersections.
- Upgrade lighting to better illuminate pedestrian crosswalks at signalized intersections..



# 8. Maintenance of Traffic

# Maintenance of Traffic

- All work will be done in phases to reduce the impact of construction to the community.
- Temporary lane closures during non-peak hours will occur.
- There will be no complete road closures.
- Access to businesses and residences will be maintained at all times.



# Project Schedule and Cost

- 90% Plans Submittal:  
**August 2022**
- 100% Plans (Production):  
**January 2023**
- Bid Opening (Letting):  
**May 2023**
- Anticipated Construction Start:  
**Fall 2023**
- Anticipated Construction Completion:  
**Spring 2025**
- Construction Cost Estimate:  
**\$4.5 Million**

# 9. Questions and Answers

# Submitting Comments or Questions

## Online Participants

- Written – Type in **Question Box** on **Control Panel** on the right side of your screen.
- Verbal – Use the raise hand icon to request to be unmuted.

## Phone Participants

- Use your telephone to call:  
1-(631) 992-3221  
Access Code: 757-584-836

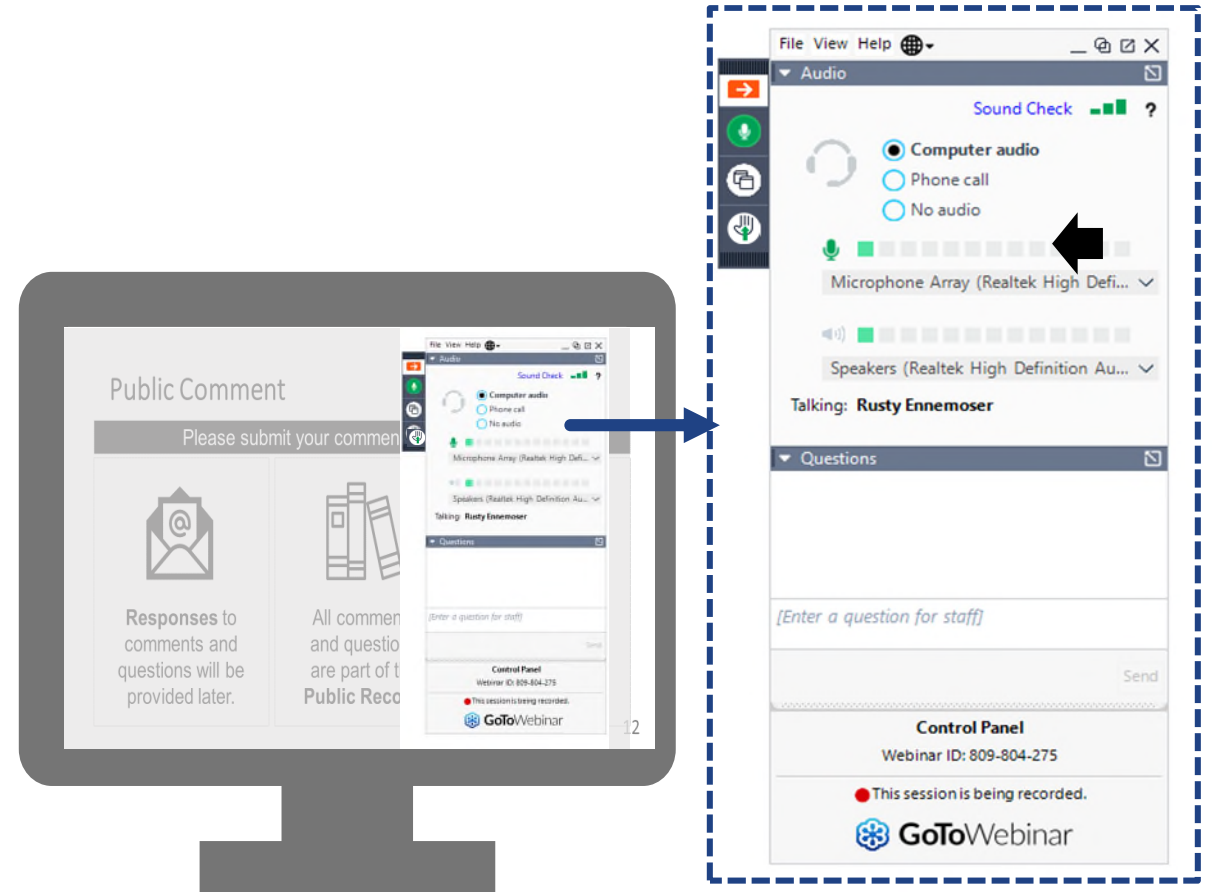

# Additional Comments & Questions

Please submit your comments by September 21, 2022



**If your question was not responded to during the event,** our project team will follow up with you.

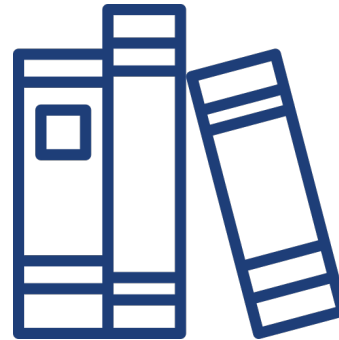

All comments and questions are part of the **Public Record**.

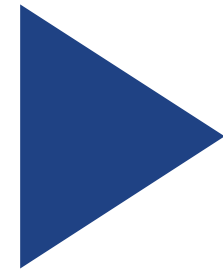

All registrants will receive a link to the **meeting recording and presentation slides**.



# 10. Contact Information

# Contact Information

Please Contact Ms. Helen James, PE, FDOT Project Manager

1. Helen.James@dot.state.fl.us



2. Helen James, PE  
 FDOT District Four  
 3400 West Commercial Boulevard  
 Fort Lauderdale, FL 33309



3. (954) 777-4346 or  
 Toll Free: (866) 336-8435; Ext. 4346



***To download presentation slides, use the link  
 and/or scan the QR code.***

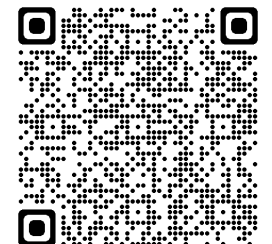



**Thank you for attending today's Public Information Meeting on the State Road (SR) 5/US 1 from SR 870/ Commercial Boulevard to SE 7th Street Resurfacing, Restoration and Rehabilitation (RRR) Project!**